

IN-LLT (Rev 1)

Submersible Level Transmitter



Installation Guide

IN-LLT Installation Guide Index:

Description.	Page 3
Ordering Information.	Page 3
Specifications.	Page 3
Construction and Dimensions.	Page 4
Construction Material.	Page 4
Dimensions.	Page 4
Unpacking, Storage and Package Contents.	Page 4
Unpacking.	Page 4
Storage.	Page 4
Package Contents.	Page 4
Installation.	Page 5
Check Before Installation.	Page 5
Installation Methods.	Page 5
Installation in Static Water.	Page 5
Installation in Flowing Water.	Page 6
Connecting up the IN-LLT.	Page 6
Connecting the IN-LLT-C 4~20mA.	Page 6
Connecting the IN-LLT-V 0~5V.	Page 6
Reference Tube Installation.	Page 6
Operation Principle.	Page 7
IN-LLT Wiring, Installation and Maintenance.	Page 8
IN-LLT Wiring & Installation.	Page 8
IN-LLT Commissioning.	Page 8
IN-LLT Maintenance.	Page 8
Fault Diagnosis.	Page 8

Product Liability. This information describes our products. It does not constitute guaranteed properties and is not intended to affirm the suitability of a product for a particular application. Due to ongoing research and development, designs, specifications, and documentation are subject to change without notification. Regrettably, omissions and exceptions cannot be completely ruled out. No liability will be accepted for errors, omissions or amendments to this specification. Technical data are always specified by their average values and are based on Standard Calibration Units at 25°C, unless otherwise specified. Each product is subject to the 'Conditions of Sale'.

Warning: These products are not designed for use in, and should not be used for patient connected applications. In any critical installation an independent fail-safe back-up system must always be implemented.

IN-LLT (Rev 1)

Submersible Level Transmitter
4~20mA Loop-Powered or 0~5Vdc

Description.

The Intech IN-LLT hydrostatic level transmitter is a fully sealed submersible pressure instrument. It is designed for liquid level measurement. The sensor and electronics are housed within a stainless steel IP68 housing and provide end users with an Industrial 4~20mA loop power or 0~5Vdc signal.

The transducer diaphragm is mechanically protected by a steel cap that is designed to allow water / product free access to the diaphragm performing the measurement. The signal cable is sealed to the housing and contains the atmospheric pressure reference tube. IN-LLT units are designed for long term submersible operation.

The IN-LLT piezo-resistive level transmitter has advantages of small size, light weight and long-term stability; it can be applied to measure and control in the petrochemical, medical, metallurgy, power station, mines, city water supply, drainage and hydrology survey and various other industries.



Ordering Information.

ITEMS	CODE		DESCRIPTION
SERIES	IN-LLT-		Hydrostatic Level Transmitter.
OUTPUT	C-		4~20mA Output (loop powered).
	V-		0~5Vdc Output.
RANGE		1	0~1 m H ₂ O with 10m Cable.
		5	0~5 m H ₂ O with 10m Cable.
		10	0~10 m H ₂ O with 15m Cable.
		20	0~20 m H ₂ O with 30m Cable.
		50	0~50 m H ₂ O with 60m Cable.
		100	0~100 m H ₂ O with 110m Cable.
		150	0~150 m H ₂ O with 160m Cable.
		200	0~200 m H ₂ O with 210m Cable.

Ordering Example.

IN-LLT-C-20: Submersible Level Transmitter with 4~20mA Output, 0~20m H₂O Range, 30m cable.

We strongly recommend that an overvoltage protection device is used with the IN-LLT if long runs of cable are involved in the installation; to protect against potential Lightning strike or earth potential rises.

Lightning Protection and Accessories.

LPN-OVP (Rev 1) DIN Rail mount OVP unit.

NAA-102 Terminal Box with filter and integral OVP.

Note: A close proximity or direct lightning strike may compromise the OVP protection.

NAA-209 Hanging Cable Clamp.

Specifications.

Range (FS) m H ₂ O	1, 2, 5, 10, 20, 50, 100, 150, 200. (See Ordering Information table.)		
Cable	Polyethylene.		
Overpressure	2 times FS.		
Accuracy	0.5% FS.		
Stability	range>20m H ₂ O, 0.2% FS.		
	range<20m H ₂ O, 20mm H ₂ O.		
Thermal Drift		Zero.	Span.
	range>10m H ₂ O	0.02% FS/°C	0.05% FS/°C.
	range>10m H ₂ O	0.05% FS/°C	0.05% FS/°C.
Operating Temperature	-10~80°C.		
Storage Temperature	-40~100°C.		
Current Output Model:	4~20mA (2-wire, Loop Powered).		
Power supply (U _T)	12~28Vdc.		
Load (Ω)	<(U _T -12)/0.02.		
Voltage Output Model:	0~5V.		
Power Supply	10~30Vdc.		
Current Draw	<3mA.		

Construction and Dimensions.

Construction Material.

Housing	Stainless Steel 1Cr18Ni9Ti.
O-Ring	Fluorine-rubber.
Rubber Bushing:	Nitrile Butadiene Rubber.
Cable:	Ø7.5mm Polyethylene Special Cable.
Diaphragm	Stainless Steel 316L.
Connection Box	Casting Aluminum (ZL102) (optional).

Dimensions.

Figure 1

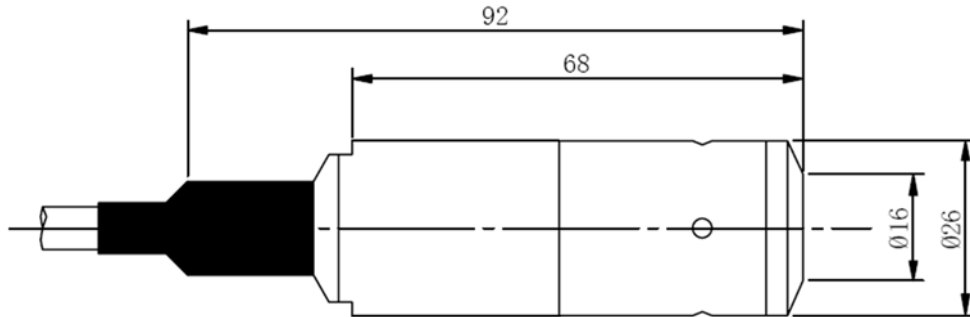

Cable Length:	Assembled according to customers' options; longest cable length up-to 500 meters.
Connection Box:	Please specify if a connection box is to be connected to the IN-LLT when ordering.
Indicator:	Only for transmitter with 2-wire, 4~20mA _{dc} output and connection box A, indicator could be provided according to the options.

Unpacking, Storage and Package Contents.

Unpacking.

Attention: Avoid knocking violently when opening to prevent damaging instruments or accessories. Please be careful to prevent damaging the housing and rubber casing of transmitter cable.

Storage.

The transmitter should be stored in dry and ventilated room with ambient temperature -40~100°C, relative humidity no more than 85% and the air in the room without corrosive gas.

Package Contents.

IN-LLT Piezo-resistive Level Transmitter	1
IN-LLT Operation Manual	1

Optional Extras and Accessories:

Quality Tracking Card	1
Product Quality Certificate	1
Polyethylene Special Cable	subject to ordered length (connected with transmitter)
Lightning Arrester Connection Box	subject to order
Hanging Cable Clamp	subject to order
Power Supply	subject to order
Indicator	subject to order

Installation.

Check before Installation.

Attention - before transmitter installation:

- The static pressure produced by the liquid at installation place exceeds the transmitter FS or not.
- The measuring liquid is compatible with the transmitter construction material or not.
- The measuring liquid may stop up the holes on the protection cap or not.

Installation Methods.

- The transmitter should be installed vertically down.
- In the flowing water, the acted surface should be parallel with the water flowing direction.

Important

- Warranty is void if water or any fluid enters the IN-LLT hose.
- Mount the IN-LLT where there is least water movement.
- The breather hole in the terminal box must exist and not be blocked. If blocked the IN-LLT will not be able to remove the effects of atmospheric pressure variation from the reading.
- Install the IN-LLT cable into the terminal box up the top end before lowering the IN-LLT transmitter into the water.
- Support and clamp the cable before the terminal box connection.
- Support the cable clear of any surface likely to chafe or damage it.
- Use only screened cabling.
- Use a quality regulated instrumentation 24Vdc power supply for the best results.
- If the IN-LLT is installed on the end of a long cable run, precautions must be taken against potential Lightning strike or earth potential rises. We recommend either the LPN-OVP or NAA-102 protection units.

Installation in Static Water.

For installation in static water.

The IN-LLT cable should be fed from top to prevent water entry into balance capillary. To prevent shaking or destroying the transmitter when pumping, the transmitter should be put away from the liquid resource (see figure 5). Otherwise it should be installed as per figure 6; protected by steel tube.

Figure 5

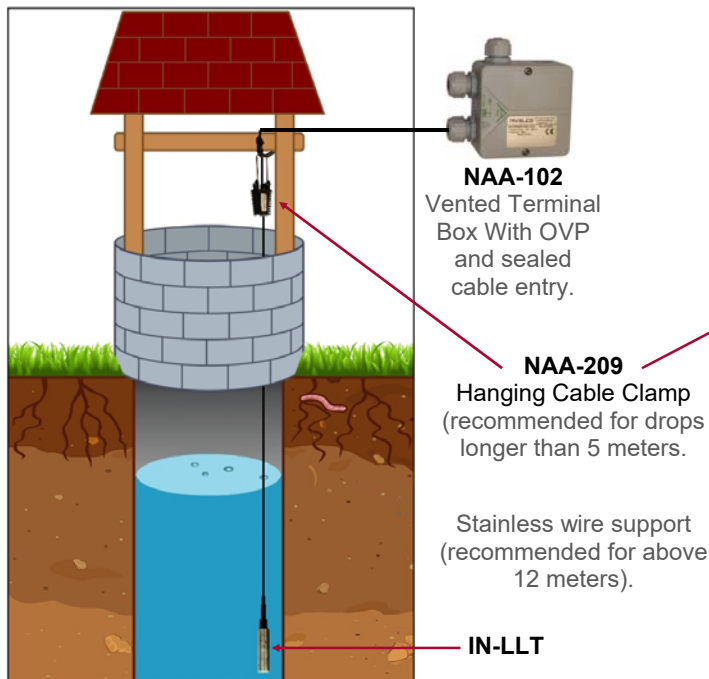
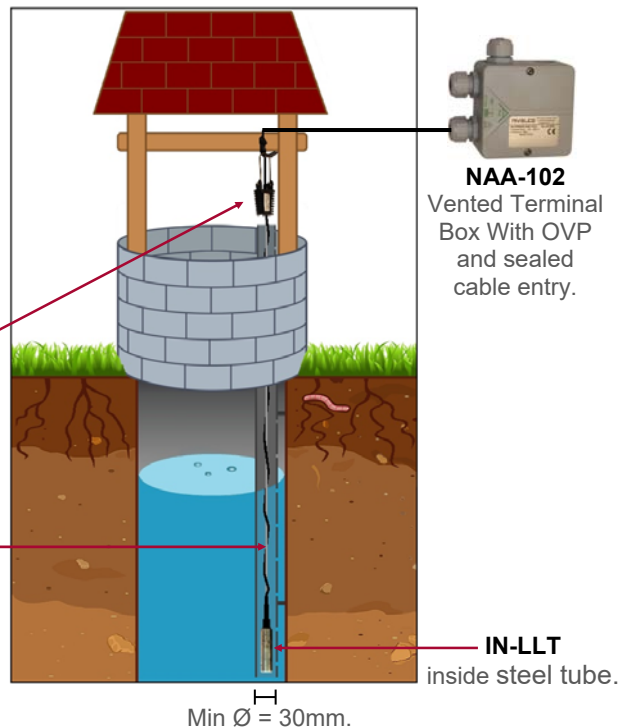

Figure 6



For installation in a deep well.

A steel tube insertion method is usually used (see figure 6). The steel tube cannot be bent; the diameter of steel tube must be more than 30mm. Several holes should be made at different heights on the tube so as to easily raising and make water flow smoothly. If necessary, wrap steel wire around transmitter to prevent breaking the cable by lifting with the steel wire.

Installation in Flowing Water (e.g. river channel, reservoir area, etc).

Water-calming equipment is required.

Figure 7

Method one: Insert a steel tube in the water channel.

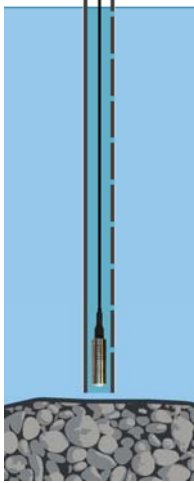

The steel tube wall should be thicker, and several holes should be made at different heights on the tube to damp waves and clear the water pressure influence.

Figure 8

Method two: This method can not only clear water flowing pressure and wave influence, but also filter the sand and mud.

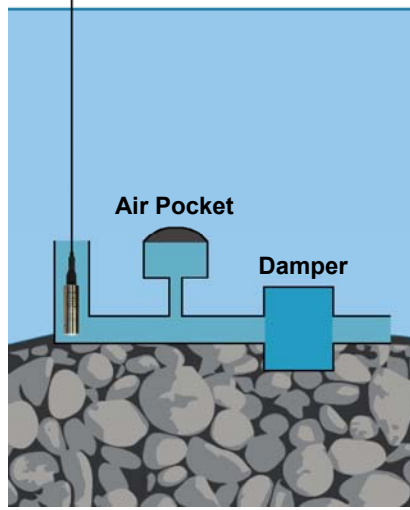

Connecting up the IN-LLT.

Wires should be connected as per the terminal definitions on the production quality certificate. See the following steps for the specified method:

Connecting the IN-LLT-C 4~20mA.

Figure 9

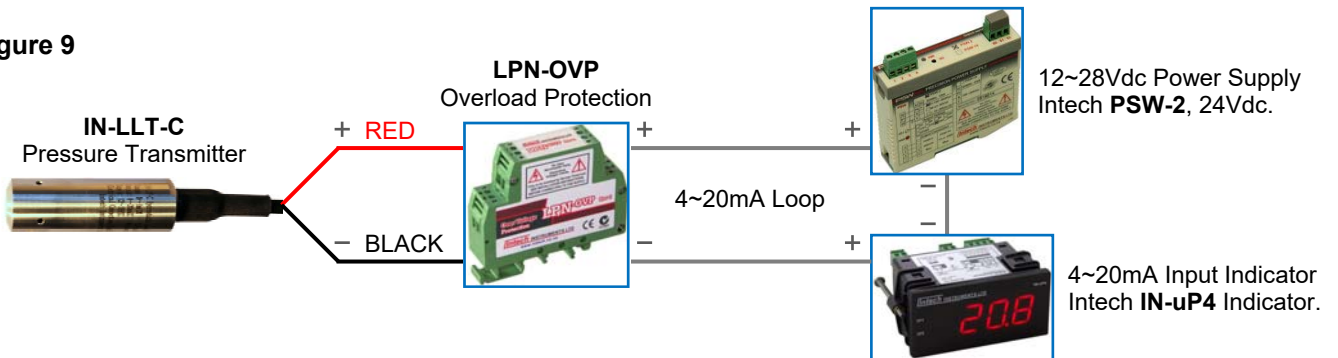

Connecting the IN-LLT-V 0~5V.

Figure 10

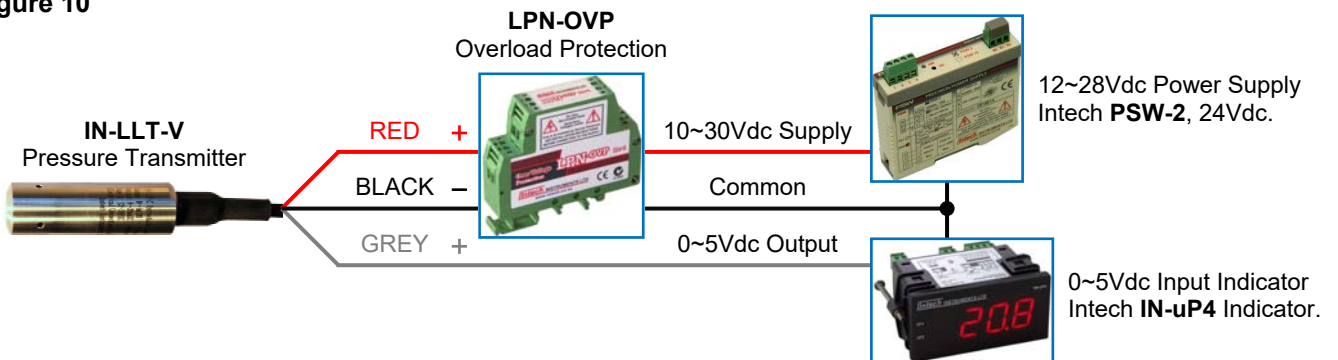

Reference Tube Installation.

There is a special plastic tube in the transmitter's cable. The back pressure cavity of the gauge sensor is connected to the atmosphere by this tube. During the process of installation and operation, be sure to keep the reference tube well connected with the atmosphere. Schedule regular cleaning to ensure ingress of foreign matter is not in or around the reference tube.

Always prevent water or any other liquid going through the reference tube which will destroy the transmitter.

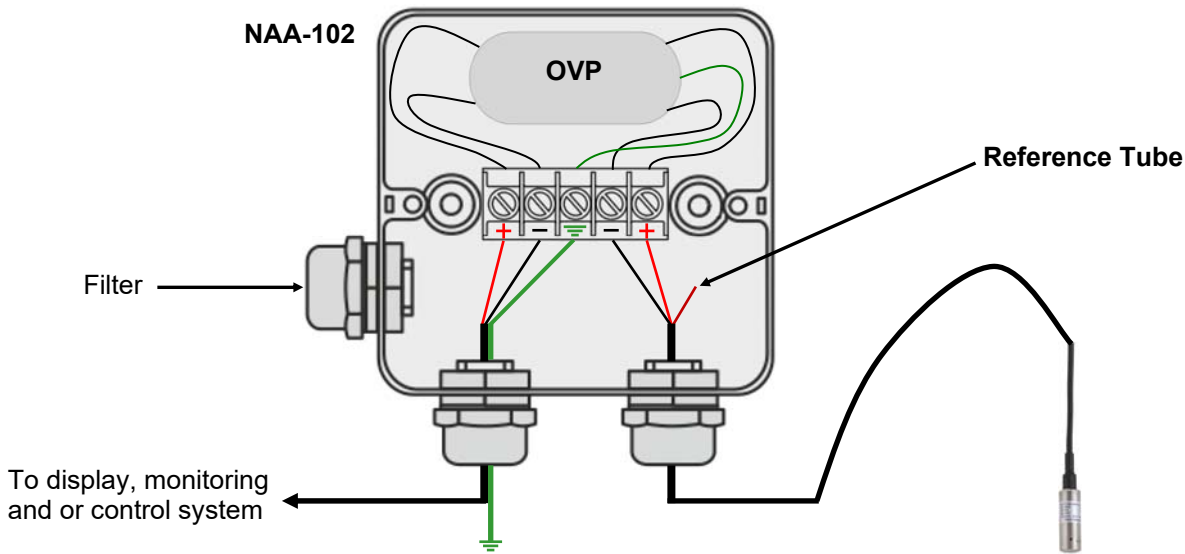

Operation Principle.

The measuring element of transmitter is a piezo-resistive sensor, which transfers the pressure into an electrical signal. The measured pressure acts on a stainless steel diaphragm, and is then transferred onto a sensitive chip by silicon oil which is filled between the stainless steel diaphragm and the sensitive chip (see figure 2).

The sensitive chip is connected to a transmitter special amplifying circuit by wires (see figure 3).

Due to the good linearity relationship between the electrical signal of Wheatstone bridge on the sensitive chip and the measured pressure, the pressure can be measured accurately.

Figure 2

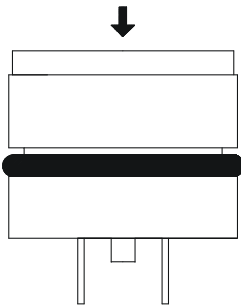
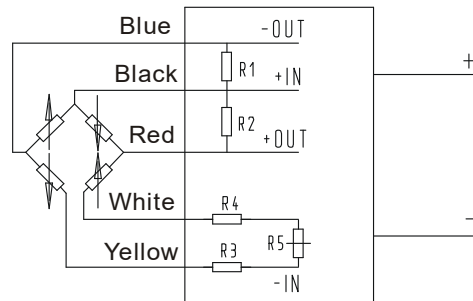

Figure 3



The basic principle of level measurement is that the liquid static pressure, proportioned with the liquid depth, is transferred into current (or voltage) signal output. The linearity corresponding relationship between electric signal output and the liquid depth is established to measure level or the liquid depth.

See figure 4 for the level measurement principle:

Figure 4

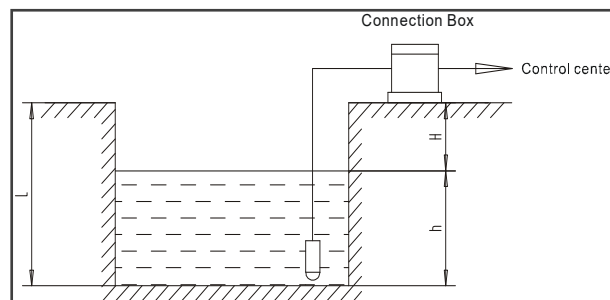

The relationship between depth and pressure:

$$P = \gamma \cdot h$$

P is the liquid static pressure at the measuring point;

γ is the liquid specific gravity;

h is the depth from the measuring point to the liquid surface, or level.

IN-LLT Wiring, Installation and Maintenance.

**THE IN-LLT TRANSMITTER IS TO BE INSTALLED AND SERVICED BY SERVICE PERSONNEL ONLY.
NO OPERATOR / USER SERVICEABLE PARTS.**

IN-LLT Wiring & Installation.

Mounting:

* Also refer to Connection Diagrams and Notes.

- 1) Mount so the terminals are in a clean environment.
- 2) Do not subject to vibration or excess temperature or humidity variations.
- 3) Avoid mounting in areas with power control equipment.
- 4) Allow 10mm minimum clearance between the terminals and ANY conductive material.

Current and Voltage Signal Wiring:

- 1) All signal cables should be good quality overall screened INSTRUMENTATION CABLE with the screen earthed at one end only.
- 2) Signal cables should be laid a minimum distance of 300mm from any power cables.
- 3) For 2 wire current loops, 2 wire voltage signals or 2 wire current signals, B5102ES is recommended.
It is recommended that you do not ground analogue signals and use power supplies with ungrounded outputs.
- 4) Lightning arrestors should be used when there is a danger from this source.
- 5) Refer to diagrams for connection information.

Power Supply Wiring:

- 1) Use Only Instrument Quality Power Supplies.
- 2) A readily accessible disconnect device and a 1A, 250Vac overcurrent device, must be in the power supply wiring.

IN-LLT Commissioning.

- 1) Once the above wiring has been thoroughly checked, apply power to the and the circuit. Allow at least a 5 minute warm-up period, sometimes up to 30 minutes is required for a more reliable output.
- 2) **Calibration Check:** Take a measurement of the value being measured (e.g. using a dipstick), and ensure that this agrees with the level being indicated on the display. Adjust for any differences. It is recommended to measure both a high and low value and compare these readings with your physical level.

IN-LLT Maintenance.

- 1) Check the IN-LLT for wear or damage and replace if defective.
- 2) Check the cables and connections to the lightning arrestor, power supply and indicator, making sure they're connected securely and undamaged.
- 3) Check the protection cap and diaphragm cavity are clean (take care!)
- 4) Do not violently pull cables or poke the diaphragm with metal or other hard objects.
- 5) Repeat (2) of commissioning. Do it regularly - at least once per year.

Fault Diagnosis.

The IN-LLT level transmitter is an integrative full-sealed construction without movable parts inside, owning advantage of long-term stability and reliability. If a failure occurs, such as no output, output too big or too small and unreliable, please turn off the excitation firstly, then check the installation as per the above section 'Maintenance'.

If unsuccessful, the transmitter may be damaged; please contact Intech Instruments.

Notes:

- 1) In the event that the IN-LLT-C units are being used with liquids other than water, please ensure that the seals and cable will not be compromised.
- 2) Two kinds of cable are available; Polyethylene (PE) & Polyurethane (PUR). Polyethylene cable is the stock standard.
- 3) If the IN-LLT is prone to lightning strikes, we strongly recommend the use of the optional NAA-102 or LPN-OVP to protect the device.
- 4) At standard conditions: (@4°C, g=9.80665 m/s²)
 1m H₂O = 0.1kgf/cm² = 9.80665kPa
- 5) For special requirements, please feel free to contact us.

Intech
Instruments

www.intech.co.nz
Christchurch Ph: +64 3 343 0646
Auckland Ph: 09 827 1930
Email: sales@intech.co.nz

IN-LLT Rev1 200524