

## Application Note

Title: Speed measurement with an APM-FREQ meter

Date: 9<sup>th</sup> March 2015

Revision: 1st

### 1. Introduction:

The APM-FREQ meter is capable of measuring speed of a rotating wheel by using an inductive sensor looking at pulses from the sensor generated by non-magnetic teeth on a wheel. Such as the systems used in the automotive ABS sensor type applications

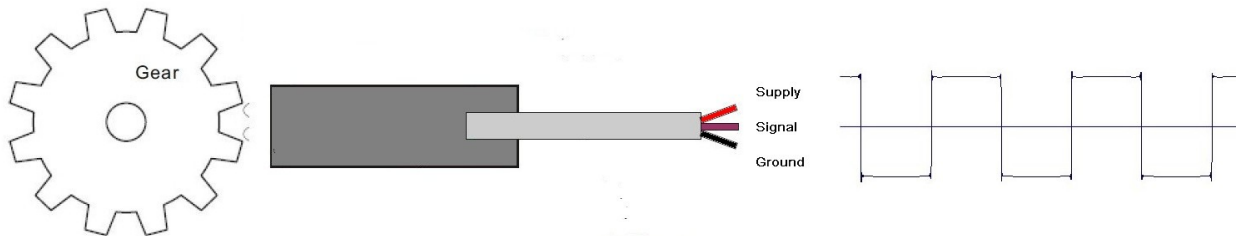

The APM-FREQ detects and measures the frequency of the output from the inductive sensor. The APM-FREQ maximum frequency is 400Hz therefore consideration must be made when designing the system to ensure that the maximum frequency from the system will not exceed this.

To enable the APM-FREQ to accurately measure the frequency the threshold voltages must be correctly set and the following sections discuss each configuration in more detail.

### 2. Setup

Using the free APM configurator software the APM-FREQ needs to be set to measure the pulses coming from the inductive pick up sensor, by setting the threshold voltages to trigger the counting circuitry such as in the diagram below:

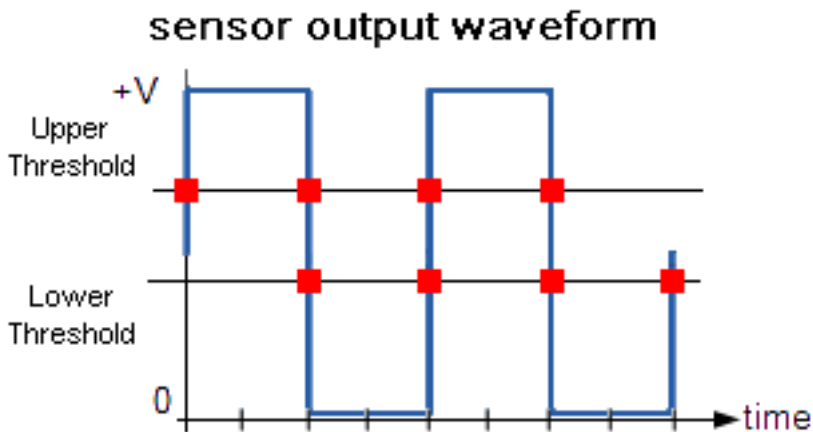

The upper threshold should be at least -10% of the maximum output voltage whilst the lower threshold should be at least 10% of the maximum output voltage, The period calculation is carried out over a 30mS sample period and an average is then calculated. Therefore any noise will lead to inaccurate calculations

The input impedance of the APM-FREQ is approximately 1.5MΩ

### 3. Wiring

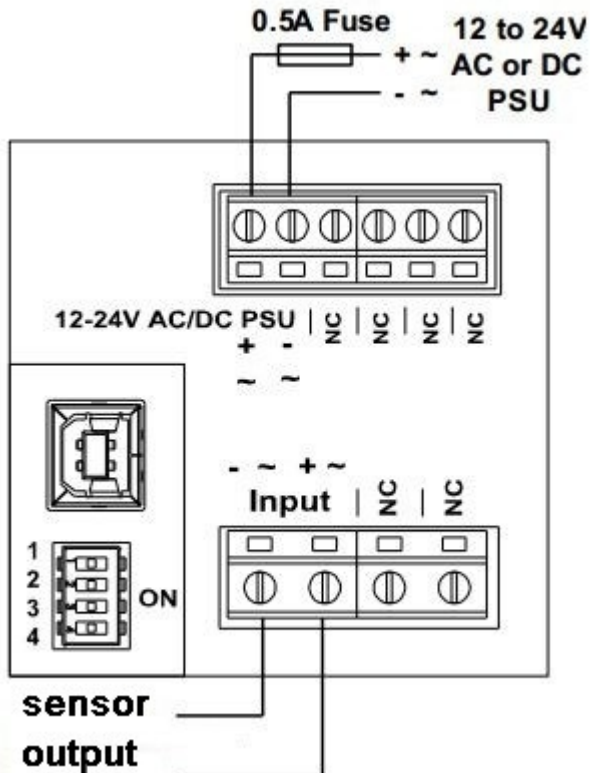

### 4. Showing RPM

In order to show a meaningful value on the display of the APM such as revolutions per minute



$$\text{RPM} = \frac{1}{\text{Number of Teeth}}$$

You must first calculate one over the number of pulses from the wheel in one revolution this figure must then be entered into the display scalar section of the APM Configurator software

For instance in the application below the wheel has 12 teeth

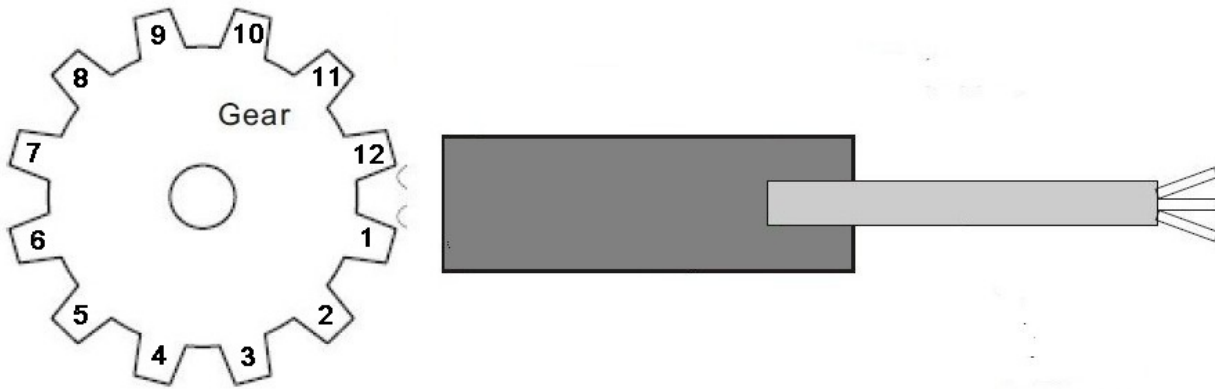

Therefore the scale required is  $1 \div 12 = 0.083$  this is then entered into the scale box which will then mean the scale on the APM can read true RPM

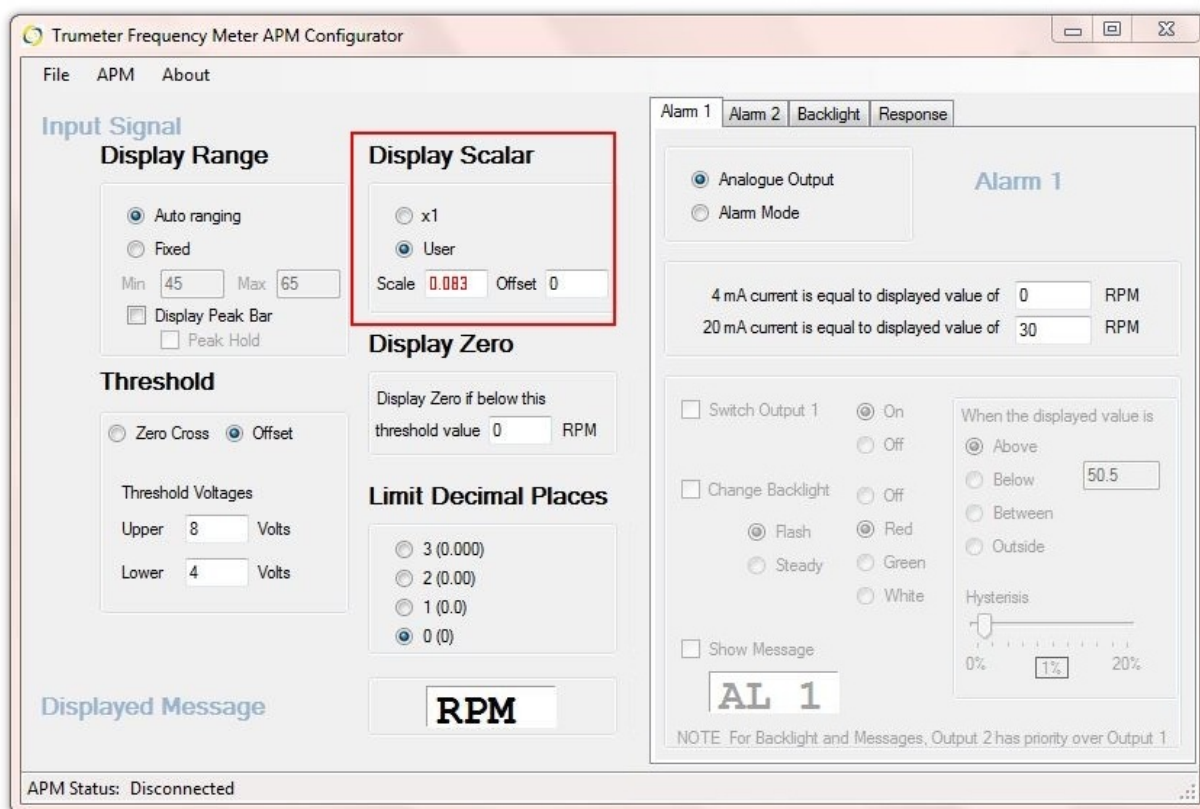

## 5. Using the outputs

We can also use the APM-FREQ-AXO to transmit a 4-20 mA signal to indicate RPM to a PLC by setting one of the Alarm outputs to Analogue Output and then by setting the upper and lower calibration set points for the speed required as above